

PU4314

Silicon NPN/PNP Epitaxial Planar Type

Power Amplifier, Switching

■ Features

- Low collector-emitter saturation voltage ($V_{CE(sat)}$)
- Good linearity of DC current gain (h_{FE})
- High speed switching
- 2 NPN elements + PNP elements

■ Absolute Maximum Ratings ($T_c=25^\circ\text{C}$)

Item	Symbol	Value	Unit
Collector-base voltage	V_{CB0}	± 40	V
Collector-emitter voltage	V_{CEO}	± 20	V
Emitter-base voltage	V_{EBO}	± 5	V
Peak collector current	I_{CP}	± 12	A
Collector current	I_C	± 7	A
Power dissipation	P_D	15	W
Junction temperature	T_j	150	$^\circ\text{C}$
Storage temperature	T_{stg}	$-55 \sim +150$	$^\circ\text{C}$

■ Package Dimensions

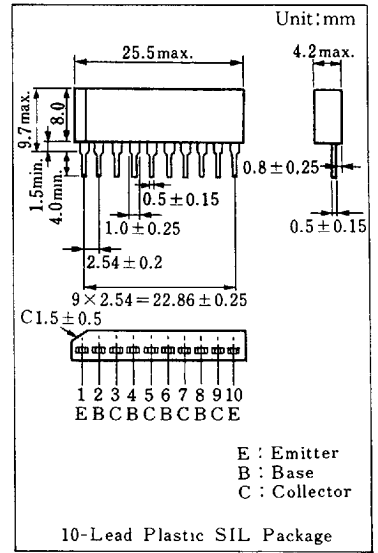

■ Inner Circuit

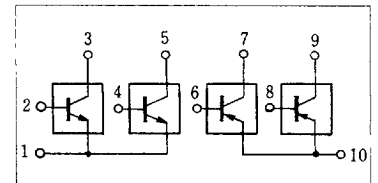

■ Electrical Characteristics ($T_c=25^\circ\text{C}$)

Item	Symbol	Condition	min.	typ.	max.	Unit
Collector cutoff current	I_{CB0}	$V_{CB} = \pm 40\text{V}, I_E = 0$			± 50	μA
Emitter cutoff current	I_{EBO}	$V_{EB} = \pm 5\text{V}, I_C = 0$			± 50	μA
Collector-emitter voltage	V_{CEO}	$I_C = \pm 10\text{mA}, I_B = 0$	± 20			V
DC current gain	h_{FE1}	$V_{CE} = \pm 2\text{V}, I_C = \pm 0.1\text{A}$	45			
	h_{FE2}	$V_{CE} = \pm 2\text{V}, I_C = \pm 2\text{A}$	60		260	
Collector-emitter saturation voltage	$V_{CE(sat)}$	$I_C = \pm 5\text{A}, I_B = \pm 0.16\text{A}$			± 0.6	V
Base-emitter saturation voltage	$V_{BE(sat)}$	$I_C = \pm 5\text{A}, I_B = \pm 0.16\text{A}$			± 1.5	V
Transition frequency	f_T	$V_{CE} = \pm 10\text{V}, I_C = \pm 0.5\text{A}, f = 10\text{MHz}$		150		MHz
Collector output capacitance	C_{ob}	$V_{CB} = \pm 10\text{V}, I_E = 0, f = 1\text{MHz}$		140		pF
Turn-on time	t_{on}	$I_C = \pm 2\text{A}, I_{B1} = \pm 66\text{mA}, I_{B2} = \mp 66\text{mA}$	(typ.) NPN: 0.3, PNP: 0.1			μs
Storage time	t_{stg}		(typ.) NPN: 0.3, PNP: 0.5			μs
Fall time	t_f		0.1			μs

6932852 0017050 790

—1051—

Panasonic

