

**TRIPLE DIFFUSED PLANER TYPE
HIGH VOLTAGE, HIGH SPEED SWITCHING**

■ **Features**

- High D.C. current gain
- High reliability

■ **Applications**

- Switching regulators
- General purpose power amplifiers

■ **Outline Drawings**

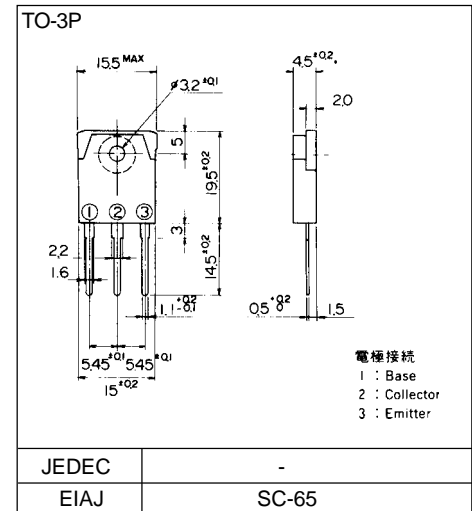

■ **Maximum ratings and characteristic**

- Absolute maximum ratings (T_c=25°C unless otherwise specified)

Item	Symbol	Rating	Unit
Collector-Base voltage	V _{CB0}	600	V
Collector-Emitter voltage	V _{CEO}	600	V
Collector-Emitter voltage	V _{CEO(SUS)}	450	V
Emitter-Base voltage	V _{EBO}	6	V
Collector current	I _C	12	A
Base current	I _B	1	A
Collector power dissipation	P _C	100	W
Operating junction temperature	T _j	+150	°C
Storage temperature	T _{stg}	-55 to +150	°C

- Electrical characteristics (T_c =25°C unless otherwise specified)

Item	Symbol	Test Conditions	Min.	Typ.	Max.	Units
Collector-Base voltage	V _{CB0}	I _{CBO} = 1mA	600			V
Collector-Emitter voltage	V _{CEO}	I _{CEO} = 1mA	600			V
Collector-Emitter voltage	V _{CEO(SUS)}	I _C = 1A	450			V
Emitter-Base voltage	V _{EBO}	I _{EBO} = 200mA	6			V
Collector-Base leakage current	I _{CBO}	V _{CB0} = 600V			1.0	mA
Emitter-Base leakage current	I _{EBO}	V _{EBO} = 6V			200	mA
D.C. current gain	h _{FE}	I _C = 12A, V _{CE} = 5V	100			
Collector-Emitter saturation voltage	V _{CE(Sat)}	I _C = 12A, I _B = 240mA			2.0	V
Base-Emitter saturation voltage	V _{BE(Sat)}				2.2	V
*1	t _{on}	I _C = 12A, I _{B1} = 240mA			1.5	μs
Switching time	t _{stg}	I _{B2} = -240mA, R _L = 20			10	μs
	t _f	P _w = 20 μs Duty=<2%			2.0	μs

- Thermal characteristics

Item	Symbol	Test Conditions	Min.	Typ.	Max.	Units
Thermal resistance	R _{th(j-c)}	Junction to case			1.25	°C/W

Characteristics

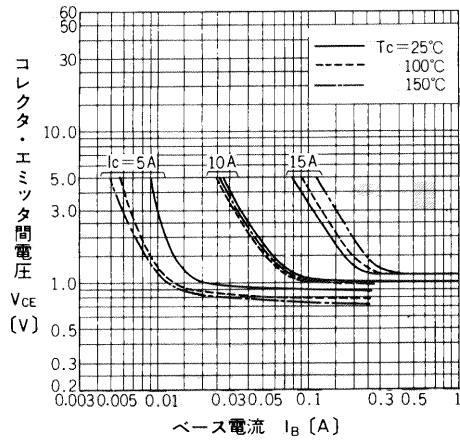

出力特性
Collector Output Characteristics

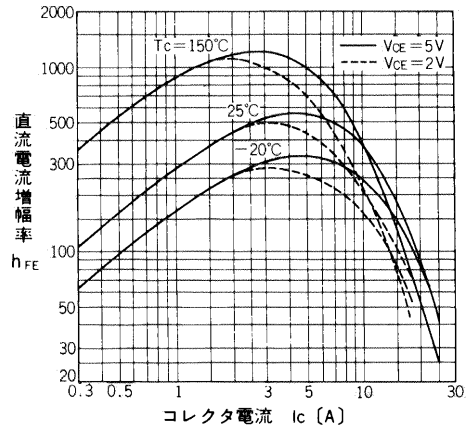

直流電流増幅率—コレクタ電流特性
DC Current Gain

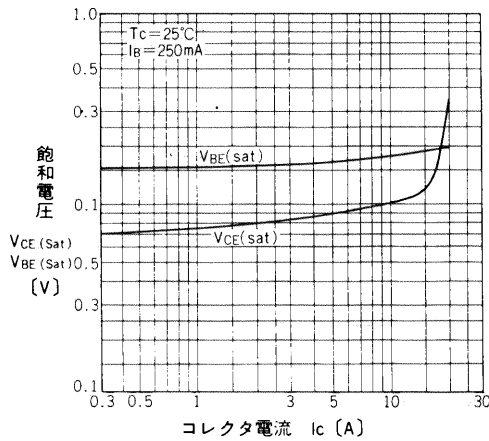

飽和電圧—コレクタ電流特性
Base and Collector Saturation Voltage

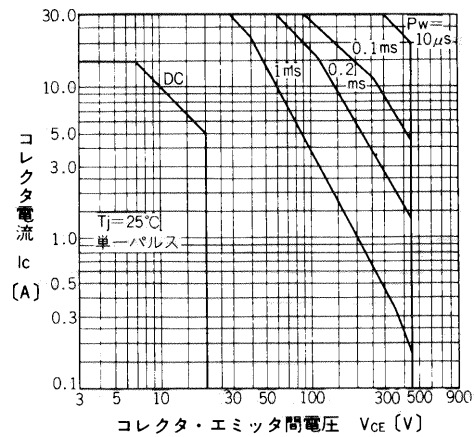

安全動作領域特性
Safe Operating Area

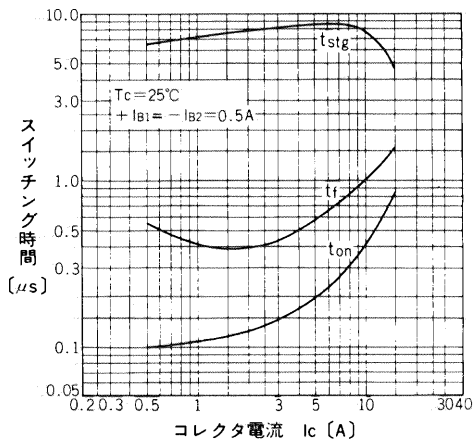

スイッチング時間—コレクタ電流特性
Switching Time

スイッチングタイム測定回路

※) Switching Time Test Circuit

