



MEAN WELL

SWITCHING POWER SUPPLY

ISO-9001 CERTIFIED MANUFACTURER

Q-60

SERIES

- .LOW COST, HIGH RELIABILITY
- .105°C OUTPUT CAPACITOR
- .INTERNATIONAL AC INPUT RANGE
- .HIGH EFFICIENCY, LOW WORKING TEMPERATURE
- .SOFT-START CIRCUIT, LIMITING AC SURGE CURRENT
- .SHORT CIRCUIT, OVERLOAD, OVER VOLTAGE PROTECTED
- .COMPACT SIZE, LIGHT WEIGHT
- .100% FULL LOAD BURN-IN TEST
- .BUILT IN EMI FILTER, LOW RIPPLE NOISE

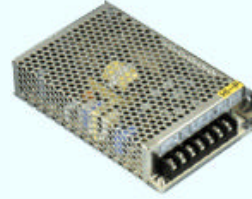

MODEL	CH1	CH2	CH3	CH4
SPECIFICATION				
DC OUTPUT VOLTAGE	5V	12V	-5V	-12V
OUTPUT V. TOLERANCE	±2%	±6%	±5%	±5%
OUTPUT RATED CURRENT	5.5A	2A	0.5A	0.5A
OUTPUT CURRENT RANGE	0.5-8A	0.1-3A	0-1A	0-1A
RIPPLE & NOISE	100mVp-p	120mVp-p	100mVp-p	120mVp-p
LINE REGULATION	±0.5%	±1%	±0.5%	±0.5%
LOAD REGULATION	±0.5%	±4%	±1%	±1%
DC OUTPUT POWER	60W			
EFFICIENCY	70%			
DC VOLTAGE ADJ.	CH1:±10,-5%			
INPUT VOLTAGE RANGE	85~264VAC 47~63Hz; 120~370VDC			
AC CURRENT	1.3A/115V 0.8A/230V			
INRUSH CURRENT	COLD START 18A/115V 36A/230V			
LEAKAGE CURRENT	<1mA/240VAC			
OVERLOAD PROTECTION	105%~150%/115VAC TYPE:PULSING HICCUP SHUTDOWN RESET:AUTO RECOVERY			
OVER VOLTAGE PROTECTION	CH1:5.75~6.75V			
OVER TEMP. PROTECTION	-----			
TEMP. COEFFICIENT	±0.03% / °C (0~50°C) ON +5V OUTPUT			
SETUP, RISE, HOLD UP TIME	1.6s, 20ms, 12ms / 115VAC 800ms, 20ms, 60ms / 230VAC			
VIBRATION	10~500Hz, 2G 10min./1cycle, PERIOD FOR 60min. EACH AXES			
WITHSTAND VOLTAGE	I/P-O/P:3KVAC I/P-FG:1.5KVAC O/P-FG:0.5KVAC			
ISOLATION RESISTANCE	I/P-O/P, I/P-FG, O/P-FG:500VDC / 100M Ohms			
WORKING TEMP., HUMIDITY	-10°C~+60°C(REFER TO OUTPUT DERATING CURVE), 20%~90% RH			
STORAGE TEMP., HUMIDITY	-20°C~+85°C, 10%~95% RH			
DIMENSION	159*97*38mm CASE:901			
WEIGHT	0.55Kgs			
SAFETY STANDARDS	UL1950 APPROVED			
EMC STANDARDS	CISPR22 (EN55022), IEC801-2,3,4, IEC555-2 VERIFICATION			

- NOTE :
- 1.ALL PARAMETERS ARE SPECIFIED AT 230VAC INPUT, RATED LOAD, 25°C 70% RH. AMBIENT.
 - 2.TOLERANCE GINCLUDE SET UP TOLERANCE, LINE REGULATION, LOAD REGULATION.
 - 3.RIPPLE & NOISE ARE MEASURED AT 20MHz BY USING A 12" TWISTED PAIR TERMINATED WITH A 0.1uF & 47uF CAPACITOR.
 - 4.LINE REGULATION IS MEASURED FROM LOW LINE TO HIGH LINE AT RATED LOAD.
 - 5.LOAD REGULATION IS MEASURED FROM 20% TO 100% RATED LOAD, AND OTHER OUTPUT AT 60% RATED LOAD.
 - 6.EACH OUTPUT PROVIDE UP TO MAXIMUM CURRENT, BUT TOTAL LOAD CAN NOT EXCEED MAX. OUTPUT POWER.
 - 7.C2,3,6 MUST BE REMOVED.

BLOCK DIAGRAM

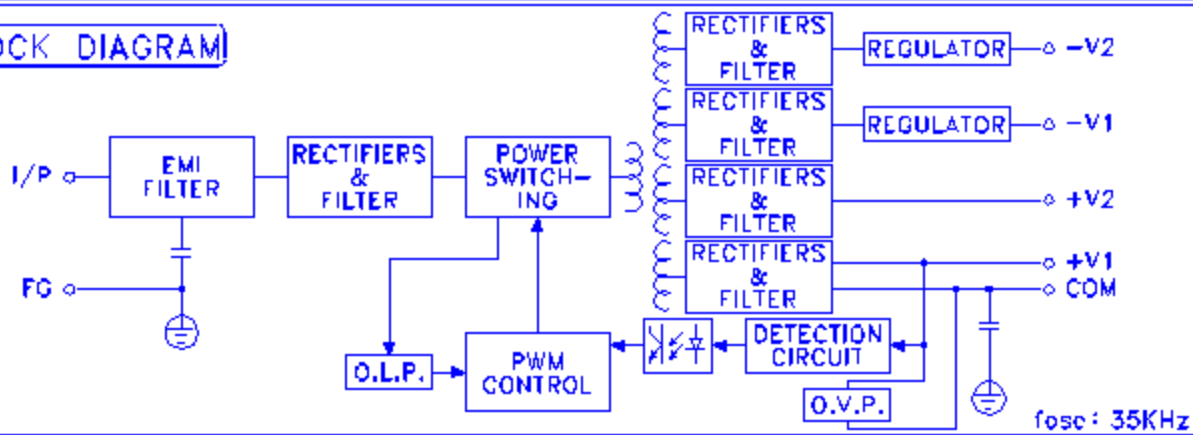

OUTPUT DERATING

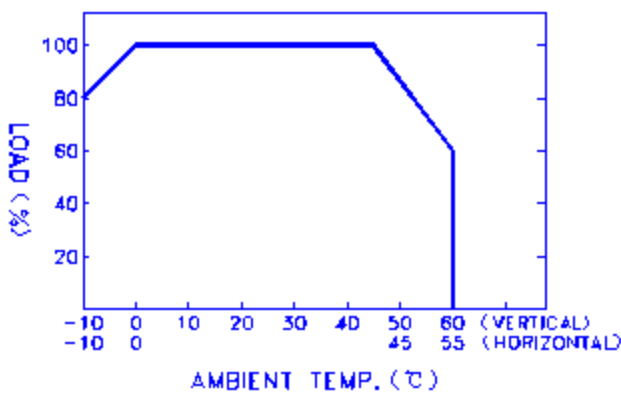

STATIC CHARACTERISTICS

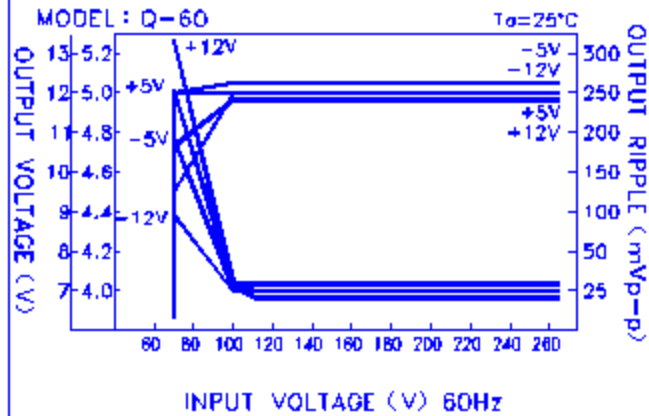

DIMENSION (mm)

- ☒ CASE : 901
- ☒ TERMINAL PIN NO. ASSIGNMENT
- ☒ PIN 1,2 : AC INPUT
- ☒ PIN 3 : FG \oplus
- ☒ PIN 4 : DC OUTPUT -V1
- ☒ PIN 5 : DC OUTPUT -V2
- ☒ PIN 6 : DC OUTPUT +V2
- ☒ PIN 7 : DC OUTPUT COM
- ☒ PIN 8 : DC OUTPUT +V1

