

RC4191/RC4192/RC4193

Micropower Switching Regulator

Features

- High efficiency – 85% typical
- Low quiescent current – 215 μ A
- Adjustable output – 1.3V to 30V
- High switch current – 200 mA
- Bandgap reference – 1.31V
- Accurate oscillator frequency – $\pm 10\%$
- Remote shutdown capability
- Low battery detection circuitry
- Low component count
- 8-lead packages

Description

The RC4191/4192/4193 series of monolithic ICs are low power switch mode regulators intended for miniature power supply applications. These DC-to-DC converter ICs provide all of the active components needed to create supplies for micropower circuits. Contained internally are an oscillator, switch, reference, comparator, and logic, plus a discharged battery detection circuit.

These regulators can achieve up to 85% efficiency in most applications while operating over a wide supply voltage range, 2.2V to 30V, at a very low quiescent current drain of 215 μ A.

The standard application circuit requires just seven external components for step-up operation: an inductor, a steering diode, three resistors, a low value timing capacitor, and an electrolytic filter capacitor. The combination of simple application circuit, low supply current, and small package make the RC4193 adaptable to a wide range of miniature power supply applications.

The RC4193 is most suited for single ended step-up ($V_{OUT} > V_{IN}$) circuits because the NPN internal switch transistor is referenced to ground. It is complemented by Raytheon's micropower switching regulator, the RC4391, which is dedicated to step-down ($V_{OUT} < V_{IN}$) and inverting ($V_{OUT} = -V_{IN}$) applications. Between the two devices the ability to create all three basic switching regulator configurations is assured. Refer to the RC4391 data sheet for step-down and inverting applications.

Block Diagram

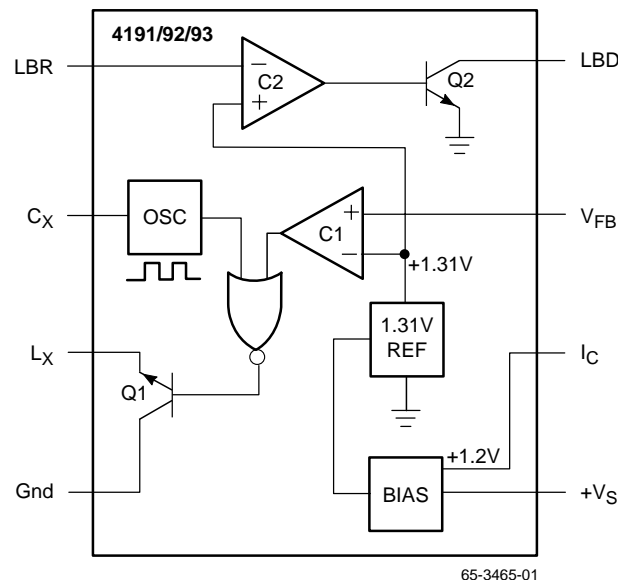

The RC4191/92/93 series of micropower switching regulators consists of three devices, each with slightly different specifications. The RC4191 has a 1.5% maximum output voltage tolerance, 0.2% maximum line regulation, and operation to 30V. The RC4192 has a 3.0% maximum output voltage tolerance, 0.5% maximum line regulation, and operation to 30V. The RC4193 has a 5.0% maximum output voltage tolerance, 0.5% maximum line regulation, and operation to 24V. Other specifications are identical for the RC4191, RC4192 and RC4193. Each type is available in commercial, industrial, and military temperature ranges, and in plastic and ceramic DIPs and S0-8 packages.

Pin Assignments

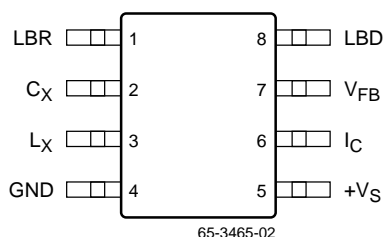

Pin Definitions

Pin Name	Pin Number	Pin Function Description
LBR	1	Low Battery (Set) Resistor
CX	2	Timing Capacitor
LX	3	External Inductor
Gnd	4	Ground
+VS	5	Positive Supply Voltage
IC	6	Reference Set Current
VFB	7	Feedback Voltage
LBD	8	Low Battery Detector Output

Absolute Maximum Ratings

(beyond which the device may be damaged)¹

Parameter		Min	Typ	Max	Units
Supply Voltage (Without External Transistor)	4191, 4192			30	V
	4193			24	V
PDTA < 50°C	SOIC			300	mW
	PDIP			468	mW
	CerDIP			833	mW
Operating Temperature	RM4191/2/3	-55		125	°C
	RV4191/2/3	-25		85	°C
	RC4191/2/3	0		70	°C
Storage Temperature		-65		150	°C
Junction Temperature	SOIC, PDIP		125		°C
	CerDIP		175		°C
Switch Current	Peak			375	mA
For T _A > 50°C Derate at	SOIC		4.17		mW/°C
	PDIP		6.25		mW/°C
	CerDIP		8.33		mW/°C

Note:

- Functional operation under any of these conditions is NOT implied. Performance and reliability are guaranteed only if Operating Conditions are not exceeded.

Operating Conditions

Parameter			Min	Typ	Max	Units
θ _{JC}	Thermal resistance	CerDIP		45		°C/W
θ _{JA}	Thermal resistance	SOIC		240		°C/W
		PDIP		160		°C/W
		CerDIP		150		°C/W

Electrical Characteristics

(+V_S = +6.0V, I_C = 5.0 μA over the full operating temperature range unless otherwise noted.)

Parameters		Conditions	4191			4192			4193			Units
			Min	Typ	Max	Min	Typ	Max	Min	Typ	Max	
+V _S	Supply Voltage		2.6		30	2.6		30	2.6		24	V
V _{REF}	Reference Voltage (Internal)		1.25	1.31	1.37	1.23	1.31	1.39	1.20	1.31	1.42	V
I _{SY}	Supply Current	Measure at Pin 5 I ₃ = 0		225	350		235	350		225	350	μA
	Line Regulation	0.5 V _O < V _S < V _O		0.2	0.5		0.5	1.0		0.5	1.0	% V _O
I _L	Load Regulation	V _S = 0.5 V _O P _L = 150 mW		0.5	1.0		0.5	1.0		0.5	1.0	% V _O
I _C	Reference Set Current		1.0	5.0	50	1.0	5.0	50	1.0	5.0	50	μA
I _{CO}	Switch Leakage Current	V ₃ = 24V (4193) 30V (4191, 4192)			30			30			30	μA
I _{SO}	Supply Current (Disabled)	V _C ≤ 200 mV			30			30			30	μA
I _{LBD}	Low Battery Output Current	V ₈ = 0.4V, V ₁ = 1.1V	400	1200		400	1200		400	1200		μA
	Oscillator Frequency Temperature Drift			±200			±200			±200		ppm/ °C

Electrical Characteristics

(+V_S = +6.0V, I_C = 5.0 μA, and T_A = +25°C unless otherwise noted.)

Parameters		Conditions	4191			4192			4193			Units
			Min	Typ	Max	Min	Typ	Max	Min	Typ	Max	
+V _S	Supply Voltage		2.2		30	2.2		30	2.2		24	V
V _{REF}	Reference Voltage (Internal)		1.29	1.31	1.33	1.27	1.31	1.35	1.24	1.31	1.38	V
I _{SW}	Switch Current	V ₃ = 400 mV	100	200		100	200		100	200		mA
I _{SY}	Supply Current	Measure at Pin 5 I ₃ = 0		215	300		215	300		215	300	μA
ef	Efficiency			85			85			85		%
	Line Regulation	0.5 V _O < V _S < V _O		0.04	0.2		0.04	0.5		0.04	0.5	% V _O
L _I	Load Regulation	V _S = +0.5 V _{OUT} P _L = 150 mW		0.2	0.5		0.2	0.5		0.2	0.5	% V _O
F _O	Operating Frequency Range		0.1	25	75	0.1	25	75	0.1	25	75	kHz
I _C	Reference Set Current		1.0	5.0	50	1.0	5.0	50	1.0	5.0	50	μA
I _{CO}	Switch Leakage Current	V ₃ = 24V (4193), 30V (4191/2)		0.01	5.0		0.01	5.0		0.01	5.0	μA
I _{SO}	Supply Current (Disabled)	V _C ≤ 200 mV		0.1	5.0		0.1	5.0		0.1	5.0	μA
I ₁	Low Battery Bias Current	V ₁ = 1.2V		0.7			0.7			0.7		μA
I _{CX}	Capacitor Charging Current			8.6			8.6			8.6		μA
	Oscillator Frequency Tolerance			±10			±10			±10		%
+V _{THX}	Capacitor Threshold Voltage +			1.4			1.4			1.4		V
-V _{THX}	Capacitor Threshold Voltage -			0.5			0.5			0.5		V
I _{FB}	Feedback Input Current	V ₇ = 1.3V		0.1			0.1			0.1		μA
I _{LBD}	Low Battery Output Current	V ₈ = 0.4V, V ₁ = 1.1V	500	1500		500	1500		500	1500		μA

Typical Performance Characteristics

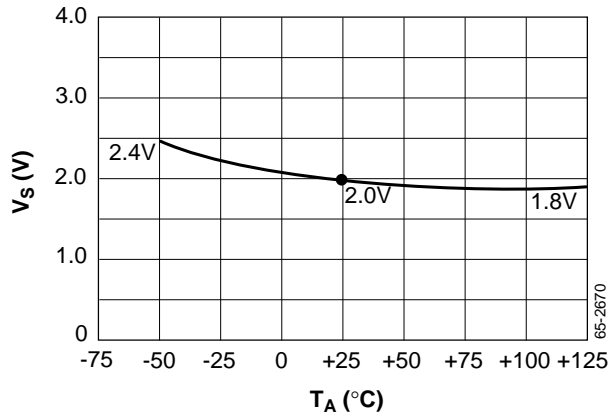

Figure 1. Minimum Supply Voltage vs. Temperature

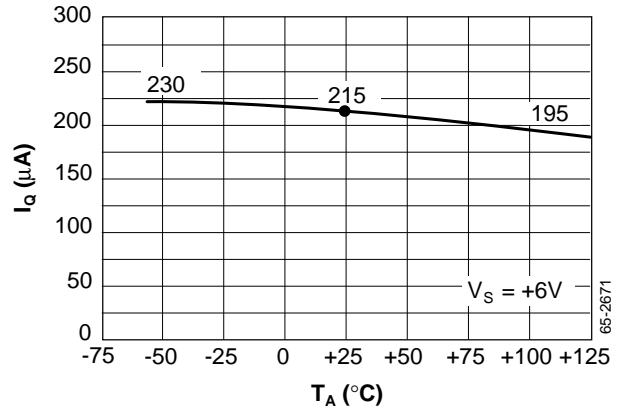

Figure 2. Quiescent Current vs. Temperature

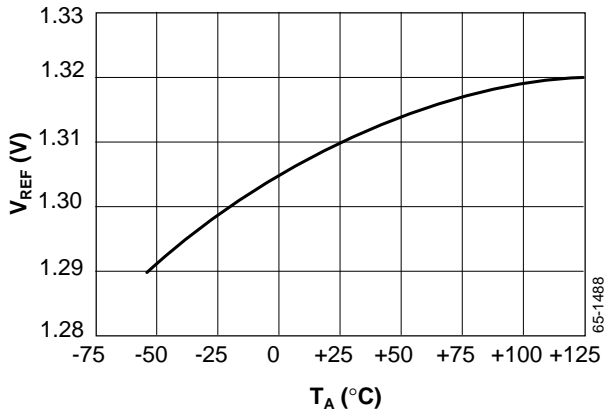

Figure 3. Reference Voltage vs. Temperature

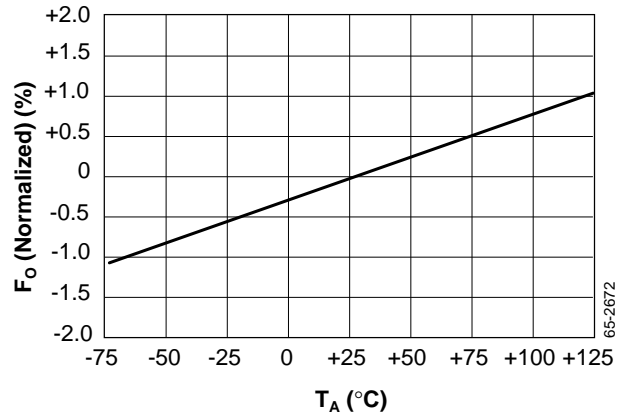

Figure 4. Oscillator Frequency vs. Temperature

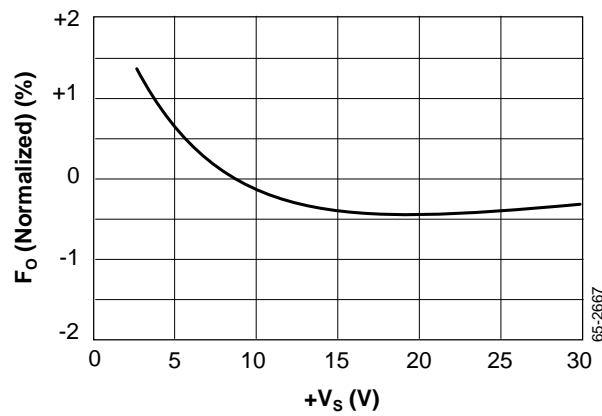

Figure 5. Minimum Supply Voltage vs. Temperature

Applications Discussion

Simple Step-Up Converter

The most common application, the step-up regulator, is derived from a simple step-up ($V_{OUT} > V_{BAT}$) DC-to-DC Converter (Figure 6).

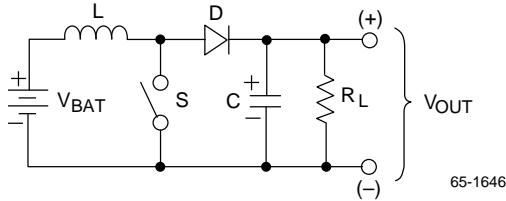

Figure 6. Simple Set-Up Converter

When switch S is closed, the battery voltage is applied across the inductor L. Charging current flows through the inductor, building up a magnetic field, increasing as the switch is held closed. While the switch is closed, the diode D is reverse biased (open circuit) and current is supplied to the load by the capacitor C. Until the switch is opened, the inductor current will increase linearly to a maximum value determined by the battery voltage, inductor value, and the amount of time the switch is held closed ($I_{MAX} = V_{BAT}/L \times T_{ON}$). When the switch is opened, the magnetic field collapses, and the energy stored in the magnetic field is converted into a discharge current which flows through the inductor in the same direction as the charging current. Because there is no path for current to flow through the switch, the current must flow through the diode to supply the load and charge the output capacitor.

If the switch is opened and closed repeatedly, at a rate much greater than the time constant of the output RC, then a constant DC voltage will be produced at the output.

An output voltage higher than the input voltage is possible because of the high voltage produced by a rapid change of current in the inductor. When the switch is opened, the inductor voltage will instantly rise high enough to forward bias the diode, to $V_{OUT} + V_D$.

In the complete RC4193 regulator, a feedback control system adjusts the on time of the switch, controlling the level of inductor current, so that the average inductor discharge current equals the load current, thus regulating the output voltage.

Complete Step-Up Regulator

A complete schematic of the minimum step-up application is shown in Figure 7. The ideal switch in the DC-to-DC Converter diagram is replaced by an open collector NPN transistor Q1. C_F functions as the output filter capacitor, and D1 and L_X replace D and L.

When power is first applied, the current in R1 supplies bias current to pin 6 (IC). This current is stabilized by a unity gain current source amplifier and then used as bias current for the 1.31V bandgap reference. A very stable bias current generated by the bandgap is mirrored and used to bias the remainder of the chip. At the same time the RC4193 is starting up, current will flow through the inductor and the diode to charge the output capacitor to $V_{BAT} - V_D$.

At this point, the feedback (pin 7) senses that the output voltage is too low, by comparing a division of the output voltage (set by the ratio of R2 to R3) to the +1.31V reference. If the output voltage is too low then the comparator output changes to a logical zero. The NOR gate then effectively ANDs the oscillator square wave with the comparator signal; if the comparator output is zero AND the oscillator output is low, then the NOR gate output is high and the switch transistor will be forced on. When the oscillator goes high again, the NOR gate output goes low and the switch transistor will turn off. This turning on and off of the switch transistor performs the same function that opening and closing the switch in the simple DC-to-DC Converter does; i.e., it stores energy in the inductor during the on time and releases it into the capacitor during the off time.

The comparator will continue to allow the oscillator to turn the switch on and off until enough charge has been delivered to the capacitor to raise the feedback voltage above 1.31V.

Thereafter, this feedback system will vary the duration of the on time in response to changes in load current or battery voltage (see Figure 8). If the load current increases (waveform C), then the transistor will remain on (waveform D) for a longer portion of the oscillator cycle (waveform B), thus allowing the inductor current (waveform E) to build up to a higher peak value. The duty cycle of the switch transistor varies in response to changes in load and time.

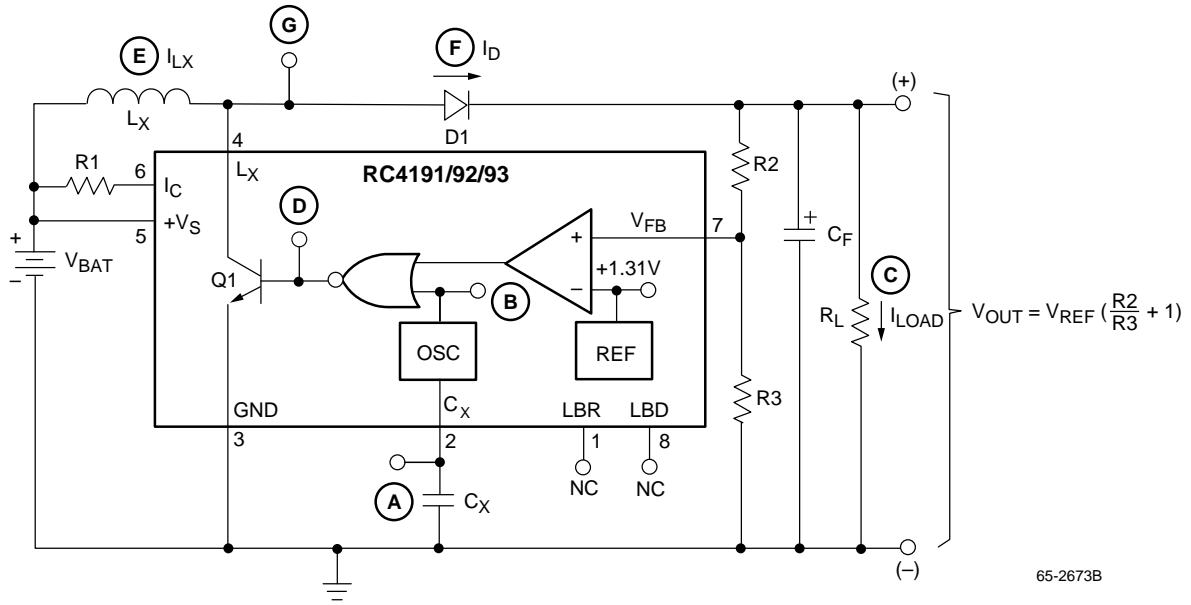

Figure 7. Complete Step-Up Regulator

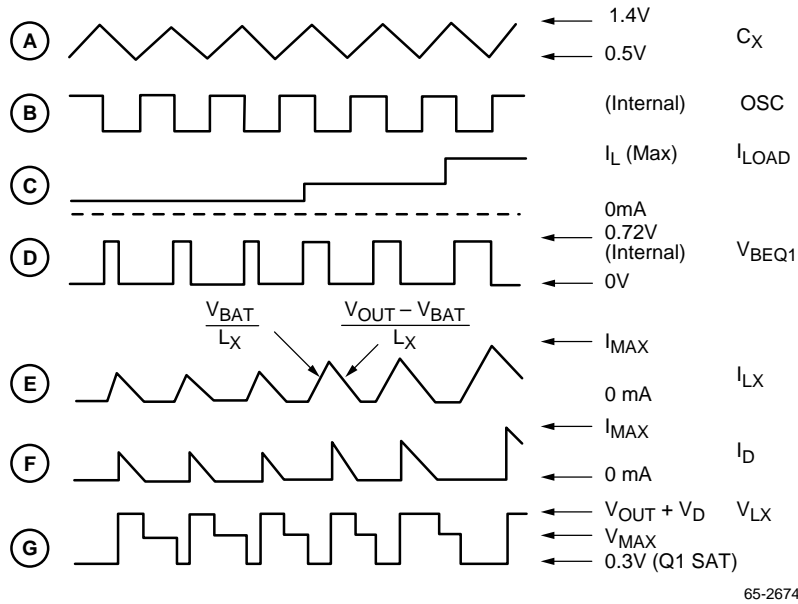
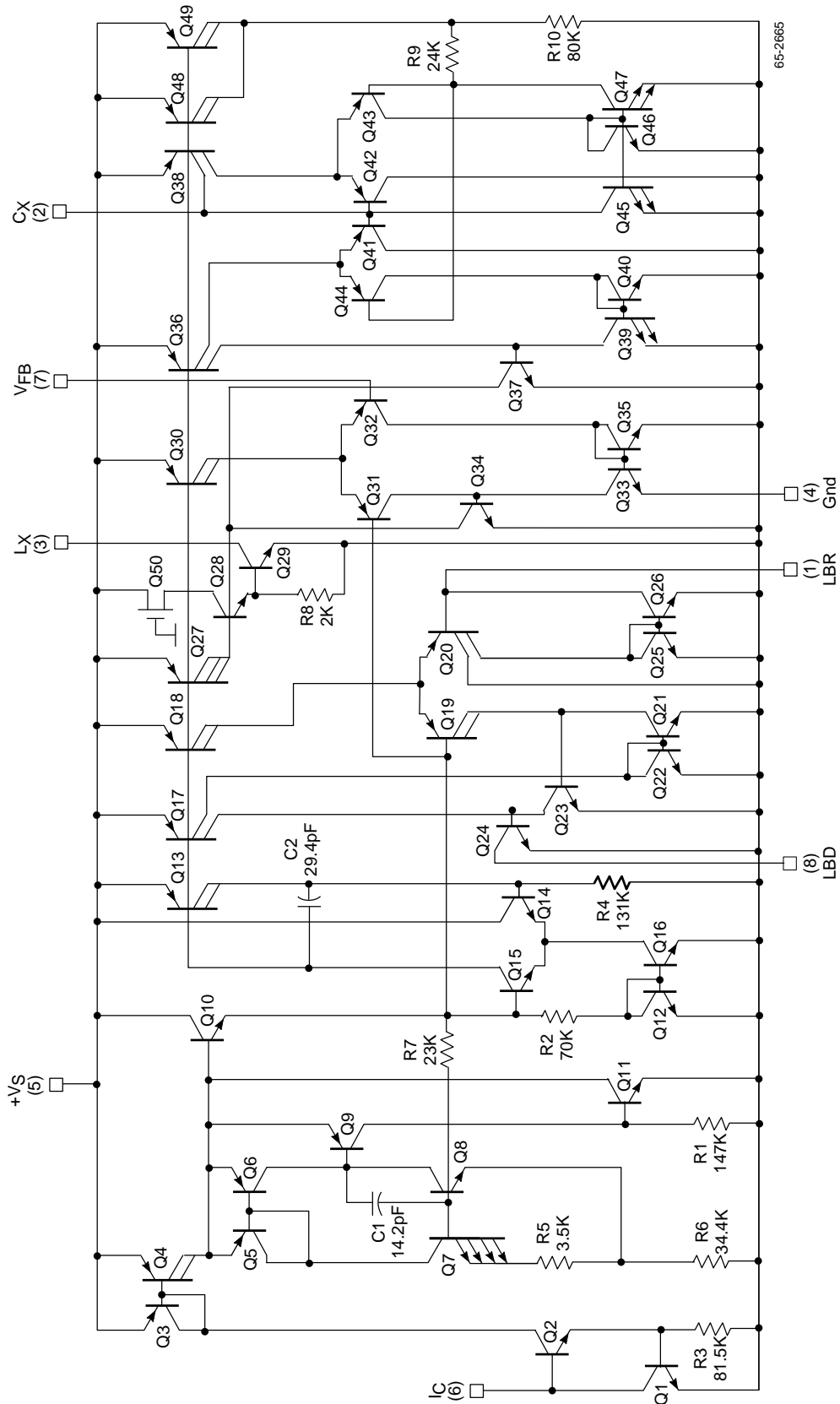

Figure 8. Step-Up Regulator Waveforms

Simplified Schematic Diagram



Mechanical Dimensions

8-Lead Ceramic DIP Package

Symbol	Inches		Millimeters		Notes
	Min.	Max.	Min.	Max.	
A	—	.200	—	5.08	
b1	.014	.023	.36	.58	8
b2	.045	.065	1.14	1.65	2, 8
c1	.008	.015	.20	.38	8
D	—	.405	—	10.29	4
E	.220	.310	5.59	7.87	4
e	.100 BSC		2.54 BSC		5, 9
eA	.300 BSC		7.62 BSC		7
L	.125	.200	3.18	5.08	
Q	.015	.060	.38	1.52	3
s1	.005	—	.13	—	6
α	90°	105°	90°	105°	

Notes:

1. Index area: a notch or a pin one identification mark shall be located adjacent to pin one. The manufacturer's identification shall not be used as pin one identification mark.
2. The minimum limit for dimension "b2" may be .023 (.58mm) for leads number 1, 4, 5 and 8 only.
3. Dimension "Q" shall be measured from the seating plane to the base plane.
4. This dimension allows for off-center lid, meniscus and glass overrun.
5. The basic pin spacing is .100 (2.54mm) between centerlines. Each pin centerline shall be located within ± 0.010 (.25mm) of its exact longitudinal position relative to pins 1 and 8.
6. Applies to all four corners (leads number 1, 4, 5, and 8).
7. "eA" shall be measured at the center of the lead bends or at the centerline of the leads when " α " is 90°.
8. All leads – Increase maximum limit by .003 (.08mm) measured at the center of the flat, when lead finish applied.
9. Six spaces.

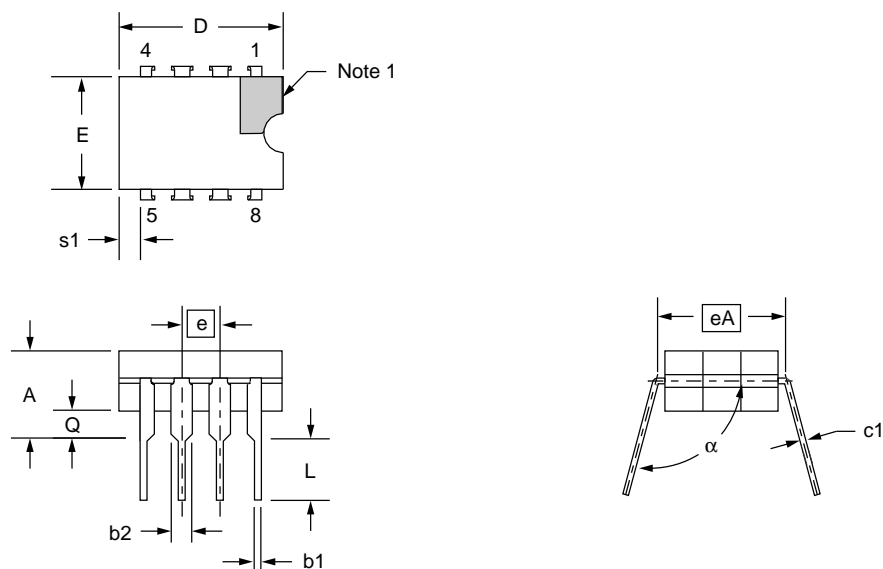

Mechanical Dimensions (continued)

8-Lead Plastic DIP Package

Symbol	Inches		Millimeters		Notes
	Min.	Max.	Min.	Max.	
A	—	.210	—	5.33	
A1	.015	—	.38	—	
A2	.115	.195	2.93	4.95	
B	.014	.022	.36	.56	
B1	.045	.070	1.14	1.78	
C	.008	.015	.20	.38	4
D	.348	.430	8.84	10.92	2
D1	.005	—	.13	—	
E	.300	.325	7.62	8.26	
E1	.240	.280	6.10	7.11	2
e	.100 BSC		2.54 BSC		
eB	—	.430	—	10.92	
L	.115	.160	2.92	4.06	
N	8°		8°		5

Notes:

1. Dimensioning and tolerancing per ANSI Y14.5M-1982.
2. "D" and "E1" do not include mold flashing. Mold flash or protrusions shall not exceed .010 inch (0.25mm).
3. Terminal numbers are for reference only.
4. "C" dimension does not include solder finish thickness.
5. Symbol "N" is the maximum number of terminals.

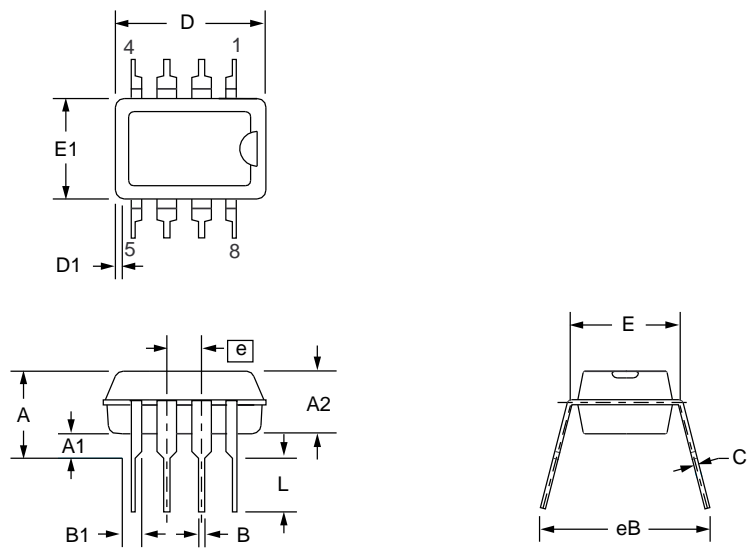

Mechanical Dimensions (continued)

8-Lead SOIC Package

Symbol	Inches		Millimeters		Notes
	Min.	Max.	Min.	Max.	
A	.053	.069	1.35	1.75	
A1	.004	.010	0.10	0.25	
B	.013	.020	0.33	0.51	
C	.008	.010	0.20	0.25	5
D	.189	.197	4.80	5.00	2
E	.150	.158	3.81	4.01	2
e	.050 BSC		1.27 BSC		
H	.228	.244	5.79	6.20	
h	.010	.020	0.25	0.50	
L	.016	.050	0.40	1.27	3
N	8		8		6
α	0°	8°	0°	8°	
ccc	—	.004	—	0.10	

Notes:

1. Dimensioning and tolerancing per ANSI Y14.5M-1982.
2. "D" and "E" do not include mold flash. Mold flash or protrusions shall not exceed .010 inch (0.25mm).
3. "L" is the length of terminal for soldering to a substrate.
4. Terminal numbers are shown for reference only.
5. "C" dimension does not include solder finish thickness.
6. Symbol "N" is the maximum number of terminals.

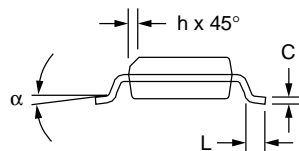
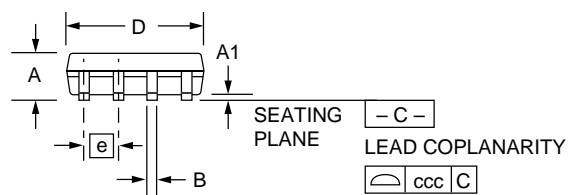
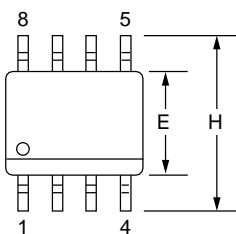

Ordering Information

Product Number	Temperature Range	Screening	Package
RC4191M/2M/3M	0° to +70°C	Commercial	8 Pin Wide SOIC
RC4191N/2N/3N	0° to +70°C	Commercial	8 Pin Plastic DIP
RV4191N/92N/93N	-25° to +85°C		8 Pin Plastic DIP
RM4191D/92D/93D	-55°C to +125°C		8 Pin Ceramic DIP
RM4191D/883	-55°C to +125°C	Military	8 Pin Ceramic DIP

Note:

1. /883 suffix denotes MIL-STD-883, Par. 1.2.1 compliant device.

The information contained in this data sheet has been carefully compiled; however, it shall not by implication or otherwise become part of the terms and conditions of any subsequent sale. Raytheon's liability shall be determined solely by its standard terms and conditions of sale. No representation as to application or use or that the circuits are either licensed or free from patent infringement is intended or implied. Raytheon reserves the right to change the circuitry and any other data at any time without notice and assumes no liability for errors.

LIFE SUPPORT POLICY:

Raytheon's products are not designed for use in life support applications, wherein a failure or malfunction of the component can reasonably be expected to result in personal injury. The user of Raytheon components in life support applications assumes all risk of such use and indemnifies Raytheon Company against all damages.

Raytheon Electronics
 Semiconductor Division
 350 Ellis Street
 Mountain View CA 94043
 650.968.9211
 FAX 650.966.7742