

5A Low Dropout Positive Regulator

FEATURES

- Dropout Voltage 1.3V at 5A Output Current.
- Fast Transient Response.
- Extremely Tight Line and Load Regulation.
- Current Limiting and Thermal Protection.
- Adjustable Output Voltage or Fixed 1.5V, 1.8V, 2.5V, 3.3V.
- Standard 3-Pin Power Packages.

APPLICATIONS

- Mother Board I/O Power Supplies.
- Microprocessor Power Supplies.
- High Current Regulator.
- Post Regulator for Switching Supply.

DESCRIPTION

The AIC1084 is a low dropout three terminal regulator with 5A output current capability. The output voltage is adjustable with the use of a resistor divider or fixed 1.5V, 1.8V, 2.5V and 3.3V. Dropout voltage is guaranteed to be at maximum of 1.4V with the maximum output current. Its low dropout voltage and fast transient response make it ideal for low voltage microprocessor applications. Current limit and thermal protection provide protection against any overload condition that would create excessive junction temperatures.

TYPICAL APPLICATION CIRCUIT

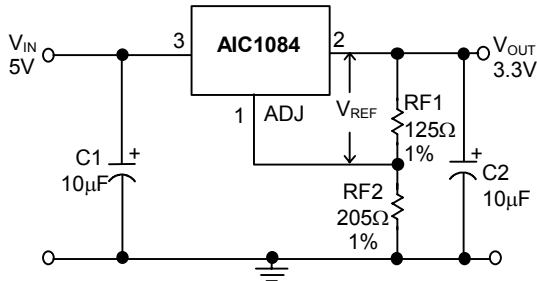

Adjustable Voltage Regulator

$$V_{REF} = V_{OUT} - V_{ADJ} = 1.25V \text{ (typ.)}$$

$$V_{OUT} = V_{REF} \times (1 + R_{F2}/R_{F1}) + I_{ADJ} \times R_{F2}$$

$$I_{ADJ} = 55\mu A \text{ (typ.)}$$

- (1) C1 needed if device is far away from filter capacitors.
- (2) C2 required for stability.

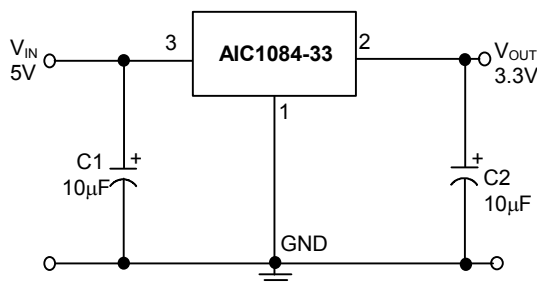

Fixed Voltage Regulator

ORDERING INFORMATION

AIC1084-XXXXXX

- PACKING TYPE
TB: TUBE
TR: TAPING & REEL
- PACKAGING TYPE
E: TO-252
M: TO-263
T: TO-220
- C: COMMERCIAL
P: LEAD FREE COMMERCIAL
- OUTPUT VOLTAGE
DEFAULT: ADJUSTABLE
15: 1.5V
18: 1.8V
25: 2.5V
33: 3.3V

Example: AIC1084-15CETR
→ 1.5V version in TO-252 Package & Taping & Reel Packing Type

Example: AIC1084-15PMTR
→ 1.5V version in TO-263 Lead Free Package & Taping & Reel Packing Type

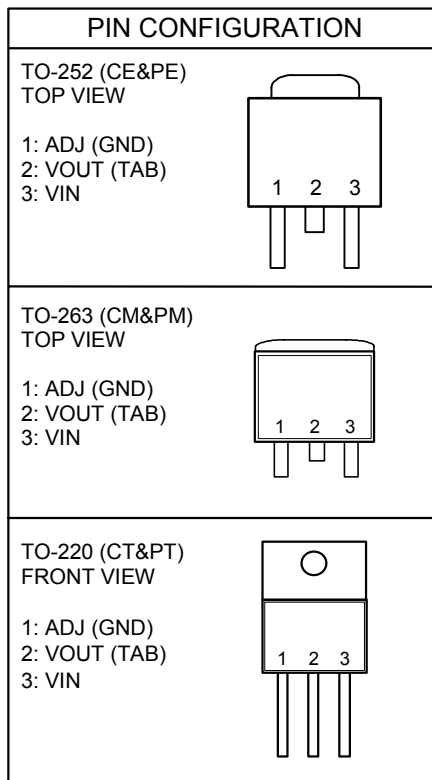

ABSOLUTE MAXIMUM RATINGS

VIN pin to ADJ/GND pin	7V
Operating Temperature Range	-40°C to 85°C
Maximum Junction Temperature	125°C
Storage Temperature Range	- 65°C ~ 150°C
Lead Temperature (Soldering) 10 sec.	260°C
Thermal Resistance Junction to Case TO-252	12.5°C/W
TO-263, TO-220	3°C /W
Thermal Resistance Junction to Ambient TO-252	100°C/W
(Assume no ambient airflow, no heatsink) TO-263	60°C /W
TO-220	50°C /W

Absolute Maximum Ratings are those values beyond which the life of a device may be impaired.

■ TEST CIRCUIT

Refer to TYPICAL APPLICATION CIRCUIT.

■ ELECTRICAL CHARACTERISTICS

($V_{IN}=5V$, $T_J=25^{\circ}C$, $I_O=10mA$, unless otherwise specified) (Note1)

PARAMETER	TEST CONDITIONS	MIN.	TYP.	MAX.	UNIT
Reference Voltage	AIC1084 (ADJ)	1.238	1.25	1.262	V
Output Voltage	AIC1084-15, $V_{IN}=5V$	1.48	1.50	1.52	V
	AIC1084-18, $V_{IN}=5V$	1.78	1.80	1.82	
	AIC1084-25, $V_{IN}=5V$	2.47	2.50	2.53	
	AIC1084-33, $V_{IN}=5V$	3.26	3.30	3.34	
Line Regulation	ADJ : $2.65V \leq V_{IN} \leq 7V$ $V_{OUT}=1.25V$		0.015	0.2	%
	Fix : $V_{OUT}+1.4V \leq V_{IN} \leq 7V$				
Load Regulation	$10mA < I_O < 5A$			0.6	%
Dropout Voltage	$\Delta V_{OUT}, \Delta V_{REF}=1\%$ $10mA \leq I_O \leq 5A$		1.3	1.4	V
Current Limit		5	6		A
GND Current (Fix)	$2.65V \leq V_{IN} \leq 7V$		11.5	14	mA
Adjusted Pin Current	$2.65V \leq V_{IN} \leq 7V$		55	120	μA
Adjusted Pin Current Change (ΔI_{ADJ})	$2.65V \leq V_{IN} \leq 7V$		0.2	5	μA
Temperature Stability	$I_O=0.5A$		0.5		%
Minimum Load Current			5	10	mA
RMS Output Noise (% of V_{OUT})	$10Hz \leq f \leq 10KHz$		0.003		%
Ripple Rejection Ratio	120Hz input ripple $C_{OUT}=25\mu F$ $(V_{IN}-V_{OUT})=3V$	60	72		dB

Note 1: Specifications are production tested at $T_A=25^{\circ}C$. Specifications over the $-40^{\circ}C$ to $85^{\circ}C$ operating temperature range are assured by design, characterization and correlation with Statistical Quality Controls (SQC).

TYPICAL PERFORMANCE CHARACTERISTICS

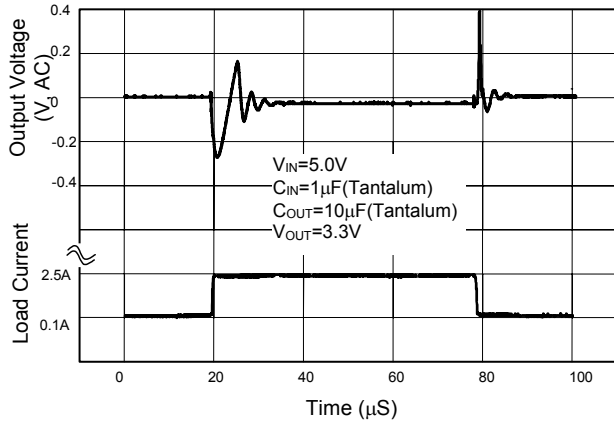

Fig. 1 Load Transient Response

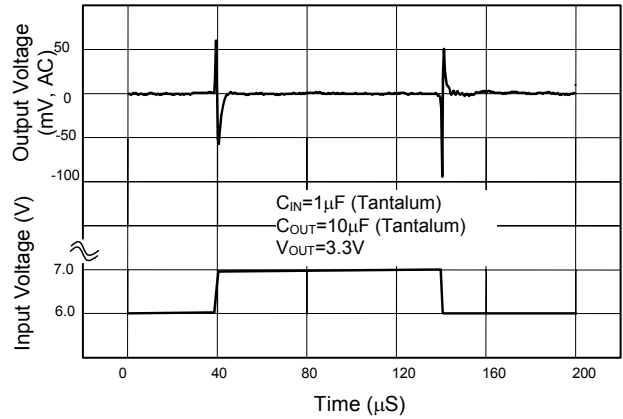

Fig. 2 Line Transient Response

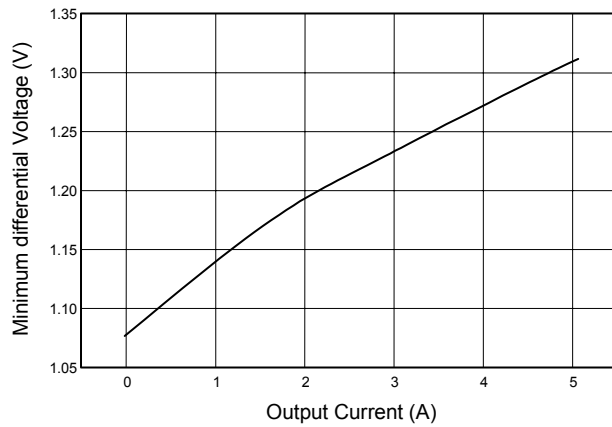

Fig. 3 Dropout Voltage ($V_{OUT}=3.3V$)

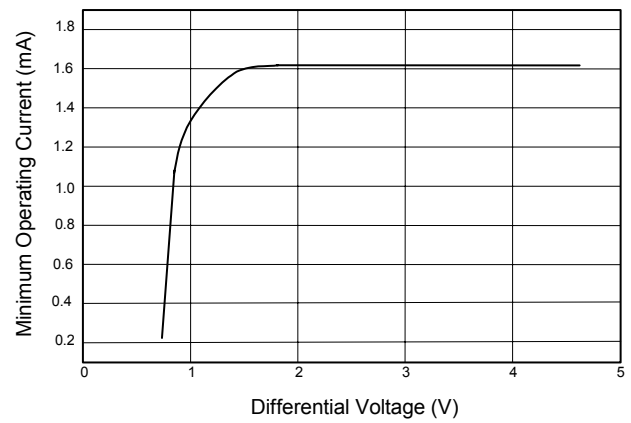

Fig. 4 Minimum Operating Current

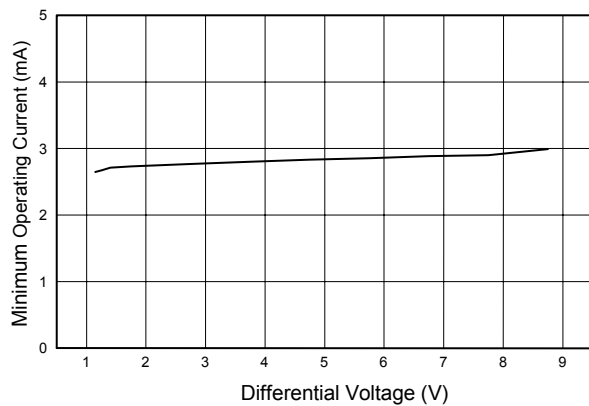

Fig. 5 Minimum Operating Current

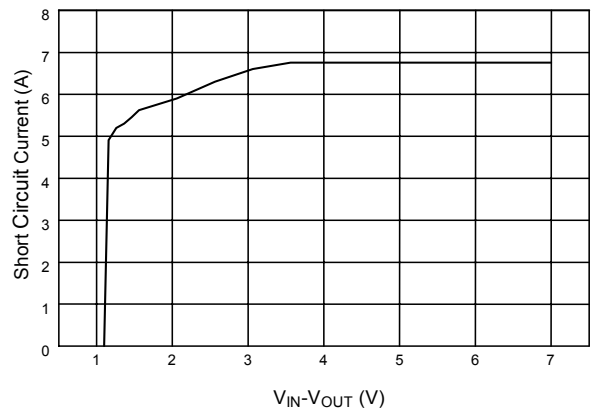

Fig. 6 AIC1084 (ADJ.) Short Circuit Current

TYPICAL PERFORMANCE CHARACTERISTICS (Continued)

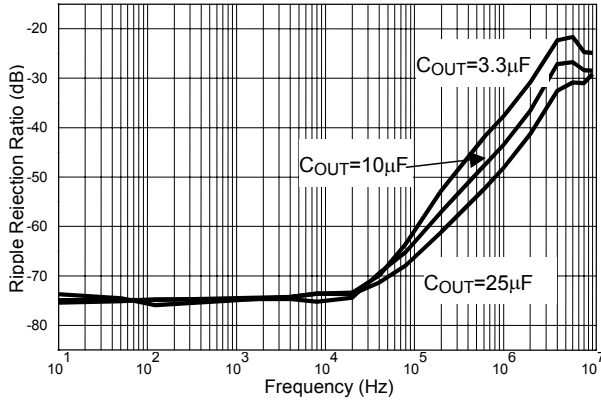
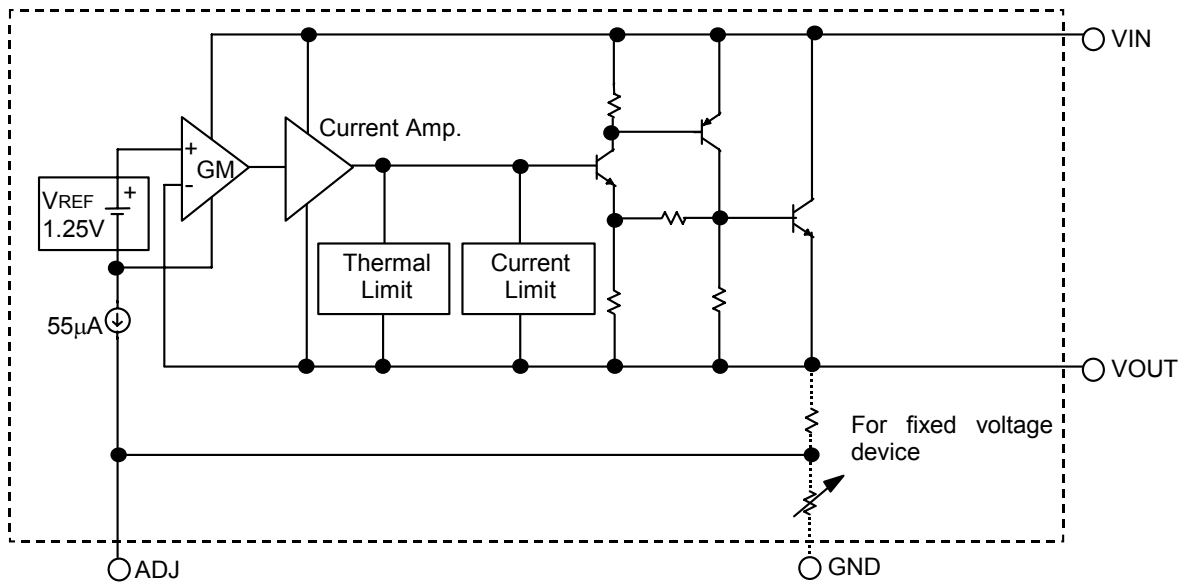

Fig. 7 AIC1084 (ADJ.) Ripple Rejection

BLOCK DIAGRAM



PIN DESCRIPTIONS

- ADJ PIN - Providing V_{REF}=1.25V (typ.) for adjustable V_{OUT}. V_{REF}=V_{OUT}-V_{ADJ} and I_{ADJ}=55µA (typ.)
- GND PIN- Power ground.
- VOUT PIN - Adjustable output voltage.
- VIN PIN - Power Input.

- TO-263 (unit: mm)

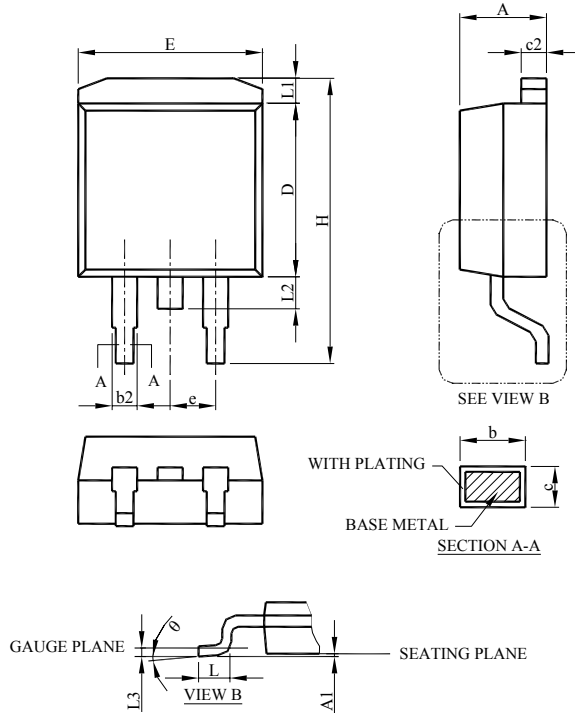

SYMBOL	TO-263-3L	
	MILLIMETERS	
	MIN.	MAX.
A	4.06	4.83
A1	0.00	0.25
b	0.51	0.99
b2	1.14	1.78
c	0.38	0.74
c2	1.14	1.65
D	8.38	9.65
E	9.65	10.67
e	2.54 BSC	
H	14.61	15.88
L	1.78	2.79
L1	--	1.68
L2	--	1.78
L3	0.25 BSC	
θ	0°	8°

Note:

Information provided by AIC is believed to be accurate and reliable. However, we cannot assume responsibility for use of any circuitry other than circuitry entirely embodied in an AIC product; nor for any infringement of patents or other rights of third parties that may result from its use. We reserve the right to change the circuitry and specifications without notice.

Life Support Policy: AIC does not authorize any AIC product for use in life support devices and/or systems. Life support devices or systems are devices or systems which, (i) are intended for surgical implant into the body or (ii) support or sustain life, and whose failure to perform, when properly used in accordance with instructions for use provided in the labeling, can be reasonably expected to result in a significant injury to the user.

This datasheet has been download from:

www.datasheetcatalog.com

Datasheets for electronics components.